

MHP Heavy-Duty Precleaner

Maximum Cleaning for the Harshes Applications

The MHP Heavy-Duty Precleaner battles the worst environments with the most abrasion-resistant urethane blade Flexco offers. Features multiple material path options and extended pole lengths to ensure it fits the application perfectly. The enormous blade provides an extended life so this heavy-duty cleaner can get the job done.

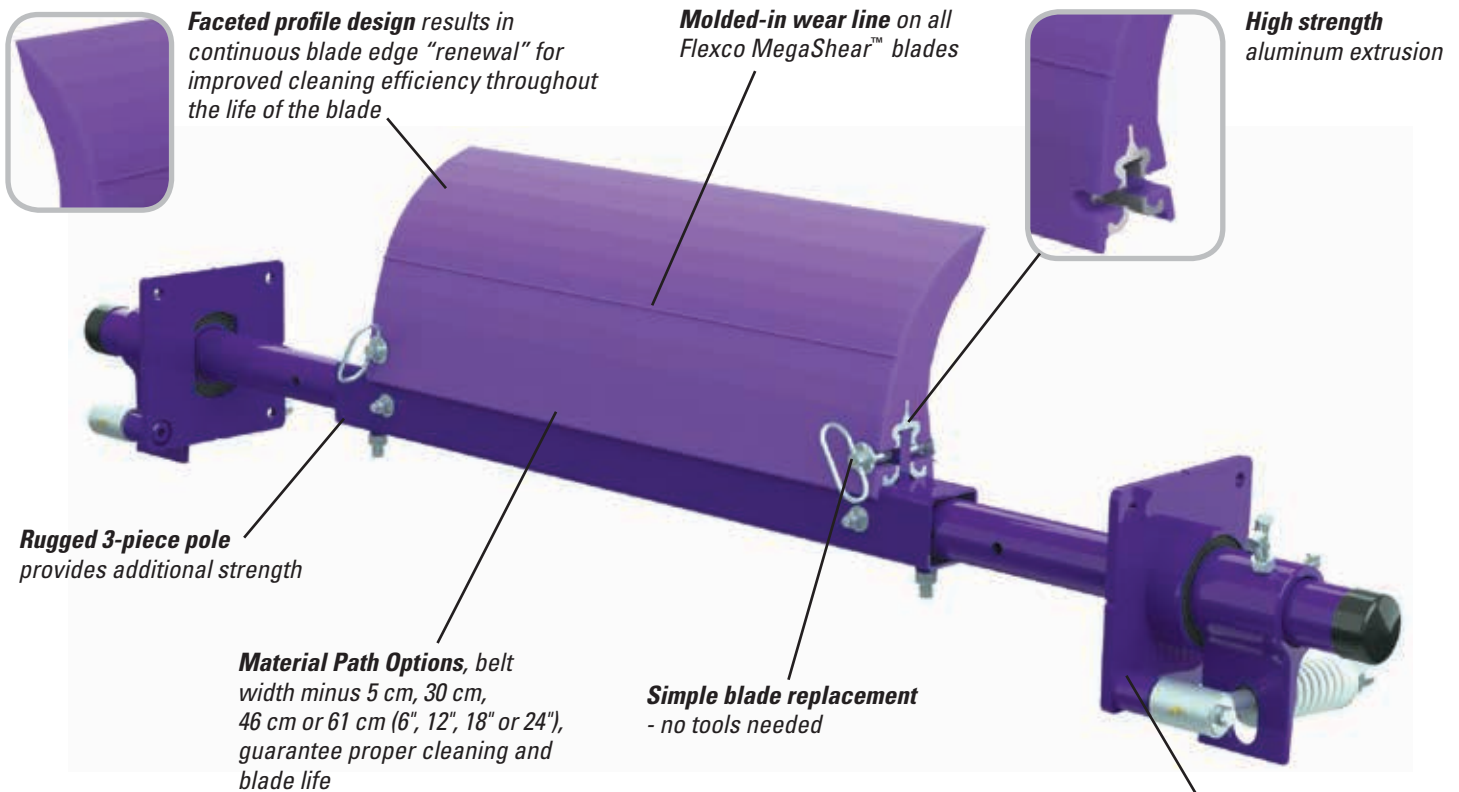

Features and Benefits

- **Versatile.** Pole length is belt width plus 1350 mm (54") to fit varying conveyor or chute wall widths. Pole extenders are available for extended length requirements.
- **Works with Flexco and other mechanical splices.** The spring tensioner quickly moves the blade away from the belt when a splice passes. The polyurethane blade easily glides over the splice without damage and with minimal cleaning disruption.
- **Made for mining conveyors.** Made from heavy-duty steel with corrosion-resistant powder coating, the MHP is available for belt widths from 600 to 2400 mm (24" to 96"). Special sizes are available upon request.
- **Complete cleaning system.** When teamed with our MHS Secondary Cleaner, it makes up a system that delivers maximum cleaning power. If extra water is present, the MDWS DryWipe can be added.

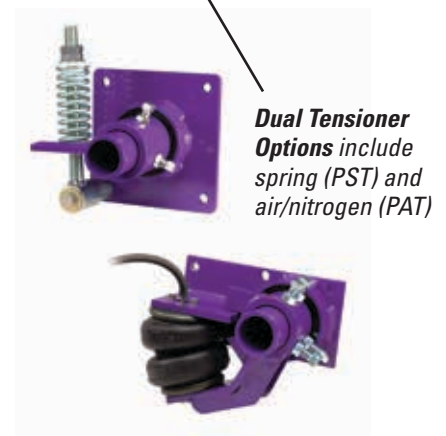

MHP Heavy-Duty Precleaner

Specifications and Guidelines

- **Maximum Belt Speed**
7.5 M/seg (1500 FPM)
- **Temperature Rating**
-35°C a 82°C (-30°F a 180°F)
- **Minimum Pulley Diameter**
500 mm (20")
- **Blade Height**
306 mm (12.25")
- **Usable Blade Wear Length**
200 mm (8")
- **Blade Material**
Urethane 90 durometer
(proprietary blend for
abrasion resistance
and long wear)
- **Available for Belt Widths**
600 mm a 2400 mm (24" a 96")

- **Horizontal Clearance Required**
200 mm (8")
- **Vertical Clearance Required**
488 mm (19.5")

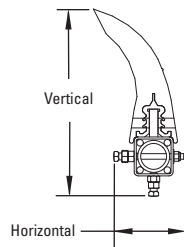

- **Pole Length**
Cleaner size + 1350 mm (54")
- **Maximum Conveyor Span**
Cleaner size + 1050 mm (42")

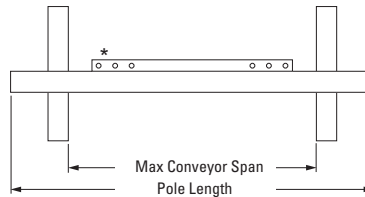

Pole Location Specs

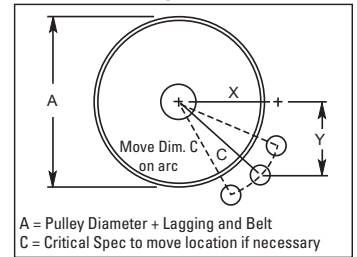

A = Pulley Diameter + Lagging and Belt
C = Critical Spec to move location if necessary

Pole Location Chart

A	X	Y	C
925	254	365	445
950	305	365	476
975	356	365	511
1000	406	365	546
1025	457	365	584
1075	508	365	625
1100	565	365	673
1125	625	365	724
1150	683	365	775
1175	740	365	826
1200	797	365	876
1225	851	365	927
1250	908	365	978
1275	962	365	1029
1300	1016	365	1080
1325	1070	365	1130
1350	1124	365	1181

See installation instructions for full pulley diameter range.

Ordering Information

MHP Precleaner - Belt Width Minus 150 mm (6")

Belt Width		Blade Width		MHP with PST Tens		MHP with PAT Tens	
mm	in.	mm	in.	Ordering Number	Item Code	Ordering Number	Item Code
600	24	450	18	MHP-624	77703	MHP-624P	78599
750	30	600	24	MHP-630	77704	MHP-630P	78600
900	36	750	30	MHP-636	77705	MHP-636P	78601
1050	42	900	36	MHP-642	77706	MHP-642P	78602
1200	48	1050	42	MHP-648	77707	MHP-648P	78603
1350	54	1200	48	MHP-654	77708	MHP-654P	78604
1500	60	1350	54	MHP-660	77709	MHP-660P	78605
1800	72	1650	66	MHP-672	77710	MHP-672P	78606
2100	84	1950	78	MHP-684	77711	MHP-684P	78607
2400	96	2250	90	MHP-696	77712	MHP-696P	78608

MHP Precleaner - Belt Width Minus 300 mm (12")

750	30	450	18	MHP-1230	77713	MHP-1230P	78609
900	36	600	24	MHP-1236	77714	MHP-1236P	78610
1050	42	750	30	MHP-1242	77715	MHP-1242P	78611
1200	48	900	36	MHP-1248	77716	MHP-1248P	78612
1350	54	1050	42	MHP-1254	77717	MHP-1254P	78613
1500	60	1200	48	MHP-1260	77718	MHP-1260P	78614
1800	72	1500	60	MHP-1272	77719	MHP-1272P	78615
2100	84	1800	72	MHP-1284	77720	MHP-1284P	78616
2400	96	2100	84	MHP-1296	77721	MHP-1296P	78617

MHP Precleaner - Belt Width Minus 450 mm (18")

900	36	450	18	MHP-1836	78591	MHP-1836P	78618
1050	42	600	24	MHP-1842	78592	MHP-1842P	78619
1200	48	750	30	MHP-1848	78593	MHP-1848P	78620
1350	54	900	36	MHP-1854	78594	MHP-1854P	78621
1500	60	1050	42	MHP-1860	78595	MHP-1860P	78622
1800	72	1350	54	MHP-1872	78596	MHP-1872P	78623
2100	84	1650	66	MHP-1884	78597	MHP-1884P	78624
2400	96	1950	78	MHP-1896	78598	MHP-1896P	78625

Lead time: 1 working day

Ordering Information

MegaShear™ Replacement Blades

Blade Width		Ordering Number	Item Code
mm	in.		
450	18	MRB-18	77531
600	24	MRB-24	77532
750	30	MRB-30	77533
900	36	MRB-36	77534
1050	42	MRB-42	77535
1200	48	MRB-48	77536
1350	54	MRB-54	77537
1500	60	MRB-60	77538
1650	66	MRB-66	77539
1800	72	MRB-72	77540
1950	78	MRB-78	77541
2100	84	MRB-84	77542
2250	90	MRB-90	77543

Other blade sizes available upon request.

MHP Precleaner - Belt Width Minus 600 mm (24")

Belt Width		Blade Width		MHP with PST Tens		MHP with PAT Tens	
mm	in.	mm	in.	Ordering Number	Item Code	Ordering Number	Item Code
1050	42	450	18	MHP-2442	78669	MHP-2442P	78676
1200	48	600	24	MHP-2448	78670	MHP-2448P	78677
1350	54	750	30	MHP-2454	78671	MHP-2454P	78678
1500	60	900	36	MHP-2460	78672	MHP-2460P	78679
1800	72	1200	48	MHP-2472	78673	MHP-2472P	78680
2100	84	1500	60	MHP-2484	78674	MHP-2484P	78681
2400	96	1800	72	MHP-2496	78675	MHP-2496P	78682

Lead time: 1 working day

Authorized Distributor:



2525 Wisconsin Avenue • Downers Grove, IL 60515-4200 • USA
Tel: (630) 971-0150 • Fax: (630) 971-1180 • E-mail: info@flexco.com

Visit www.flexco.com for other Flexco locations and products.

©2015 Flexible Steel Lacing Company. 01/15. For reorder: X3814

